USER MANUAL

EN

TempSen® Alpha T30 / TH30 / T50X / TD80 / TD80S / TUX

UM-ALPHA-140821 REV.D

Updated@ 07/06/2015

www.alphalogger.com
www.eofirm.com

Contents

Products Overview.....	4
Specifications	5
TempCentre Software.....	7
How to download TempCentre software?.....	7
Installing and using TempCentre software	7
Data Logger Configuration	7
Configuring with TempCentre	7
Configuring Online.....	7
Fast Configuration Mode	8
Applying Configuration	8
Configuration Options.....	9
→ Trip Number	9
→ Trip Description.....	9
→ Logging Mode	9
→ Logging Interval	10
→ Startup Mode	10
→ Alarm Settings.....	12
→ PDF Report Settings.....	12
Recording	13
Start recording.....	13
→ Manual Start.....	13
→ Auto Start	13
In Recording	14
→ Overall Alarm Status (Default Screen).....	14
→ Overall Limit Violation Events (Default Screen).....	14
→ Monitoring Statistics and Alarm Information	15
Time Mark.....	16
Adding a Time Mark.....	16
Trimming Data with Mark points.....	16
Stopping recording.....	17
Downloading Data	17
→ Downloading data via TempCentre.....	17
→ Accessing data by copying PDF report.....	17
PDF Report.....	18
Battery and Duration.....	20
Battery Life/Run Time	20
Accessories	21
External Sensor Probes	21
→ Installing and Removing External Probe.....	21
Mounting Bracket.....	22
Calibration Management	22

Sensors.....	23
Response Time (Temperature).....	23
→ Response Time Test	23
MKT	23
Why is MKT important in the life of pharmaceuticals and perishable goods?.....	23
Time Error	24
Additional Information	24
Warranty	24
Revision History	25

Products Overview

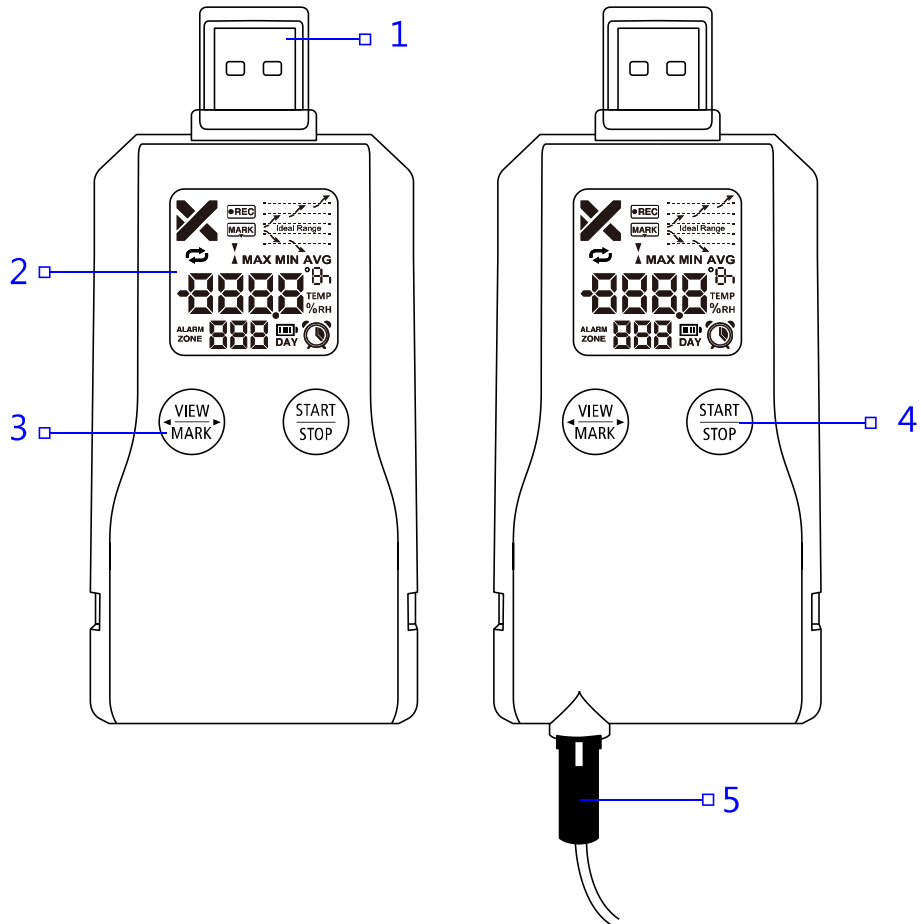

1. USB plug
2. LCD Screen
3. View / Mark button
4. Start / Stop button
5. External Sensor Probe¹

¹ Only available on products supporting external sensors.

Specifications

Product	Alpha T30	Alpha TH30	Alpha T50X	Alpha TD80/TD80S	Alpha TUX
Type	Multi-use			Multi-use TD80 Single-use TD80S	Multi-use
Sensor	Internal NTC	Internal temperature and humidity Sensor	Interchangeable external NTC Sensor (1m)	Internal RTD Sensor	Interchangeable external RTD sensor (2m, 3 sensors optional)
Memory Capacity	28800 readings	14400 readings	28800 readings	14400 readings	28800 readings
Measurement Range	-30°C...70°C (-22°F...158°F)	-30°C...70°C (-22°F...158°F) 0% RH...100% RH	-50°C...70°C ¹ (-58°F...158°F)	-80°C...70°C (-112°F...158°F)	-200°C...250°C ¹ (-328°F...482°F) Type1: -70°C...250°C Type2: -100°C...150°C Type3: -200°C...150°C
Accuracy	±0.5°C/0.9°F	± 0.5 °C/0.9°F(0°C...60°C/32°F...140°F) ± 1°C/1.8°F(rest range) ± 3% RH (20% RH...80% RH) ± 4% RH (rest range) *RH Accuracy stated at temperature condition of 20±2°C/68±3.6°F	±0.5°C/0.9°F	±0.5°C/0.9°F TD80 0.5°C/0.9°F (-30°C...30°C/-22°F...86°F) ± 1°C/1.8°F (rest range) TD80S	±0.5°C/0.9°F(-100°C...100°C/-148°F...212°F) ±1°C/1.8°F(rest range)
Resolution	0.1°C /°F 0.1% RH *Alpha TH30				
Logging Interval	1 minute...2 hours				
Logging Mode	Start & Stop/Loop				

Alarm Range	High and low alarm/5 alarm ranges				
Battery	3.6V lithium battery				
Typical Run Time	900 days	900 days	900 days	120 days (60 days@-80°C) TD80 30 days (15 days@-80°C) TD80S	900 days
Shelf Life	1 year	1 year	1 year	2 years	1 year
Automatic Data File	Encrypted PDF report with embedded raw data				
Dimensions	107mm L x 48mm W x 12mm H			107mm L x 56mm W x 18mm H	107mm L x 48mm W x 12mm H
Weight	Approx. 65g	Approx. 65g	Approx. 75g	Approx. 62-80g	Approx. 65g (exclude external probe)
Packaging/ Material	Case/Polycarbonate				
Protection Class	IP54				

- ¹ Measurement range is applied to external sensor probe(s), operation temperature range for logger body is -30 to 70°C, so please do not put logger body into environment outside of logger body operation range to avoid damage to device.

TempCentre Software

Please download and install the latest version of TempCentre software from www.eofirm.com.

- Alpha series data loggers only compatible with TempCentre 2.0 or higher.
-

How to download TempCentre software?

- If it's your first time to download software from www.tempsen.com, please sign up with the information required prior to downloading, then an email containing download link would be sent to the mail address you left in couple of minutes.
- If you want to download the software from www.eofirm.com again after your successful registration last time, please click "I already signed up, download now" button in dialog box, then software would begin to download in couple of minutes.

Installing and using TempCentre software

Please refer to TempCentre User Manual for installation and operation instructions of TempCentre software.

Data Logger Configuration

Configuring with TempCentre

Connect Alpha logger to USB port of PC, open TempCentre software, select **Configure Device** in tool bar, software would automatically start searching and connecting devices, then user could start programming of this data logger.

Configuring Online

Connect Alpha logger to USB port of PC, open Internet Browser, go to www.alphalogger.com, input configuration parameters, then download the configuration profile (.cfg format file) and save it into the logger created removable storage device "TempSenDisk".



LCD displays "USB" when logger connected to PC.



IMPORTANT

- Do not apply configuration profile to product for which the configuration profile is not created.
- Do not alter the configuration profile downloaded to avoid configuration error.
- Configuration profile contains time zone information, so please do not use this file in area of different time zone.

Fast Configuration Mode

The generation of auto PDF report sometimes will cost 10 to 30 seconds, and device is not to be configured before PDF generation completes, so to speed up the configuration process, you could press and hold both **View/Mark** and **Start/Stop** button to have logger enter into **FAST** mode, to skip PDF report generation, and start configuration right away.



Device will quit **FAST** mode after 10 seconds if there is no USB connection following.

Applying Configuration



LCD displays "Conf" for configuration success when connection with PC remains.



LCD displays "**Err**" for configuration failure, please re-configure device with correct parameters.



IMPORTANT

- Configuration to data logger would erase all data recorded, so please make sure you have save the data before configuration.
- Do not remove data logger from PC before you are prompted of configuration success.

Configuration Options

→ Trip Number

A unique 10 digits alphanumeric number automatically created for identifying each monitoring task.

→ Trip Description

A brief note entered by user for describing monitoring task and showing on data report.

→ Logging Mode

↻ Standard (Start/Stop)

Logger stops recording until memory is full.

↻ Loop (Endless)

Recording continues even memory is full under this mode, new data point overrides old data point in memory, logger provides monitoring and alarm statistics over entire monitoring course. Data points available will be the latest full memory readings.

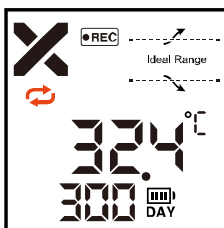

“↻” displays when Loop recording is enabled.

-
- You need to stop recording through TempCentre software if you configured device with both
 - Loop Recording and [Disable Stop Button](#).
 - Alpha TD80 / 80S do not support loop recording.
-

→ Logging Interval

The recording and sampling interval for data logger, optional from 1 minute to 2 hours.

→ Startup Mode

☞ Manual Start

Device needs to be started by pressing **Start/Stop** button for **3** seconds, and 2 additional options available under this mode, select one between the two.

1. Start Delay

The time device needs to wait before starting recording after manually activated, optional from 1 minute to 30 days.

2. Condition Start (Temperature Start)

This function allows loggers to start recording when environment temperature meets pre-set temperature condition, after setting a logger to condition start, you need to start logger to measure environment temperature by pressing **Start/Stop** button for 3 seconds, then when environment temperature meets the start condition, logger would start recording automatically.

There are three temperature start conditions available:

- **Over**, device would start recording when temperature goes over the temperature value preset.
- **Under**, device would start recording when temperature goes under the temperature value preset.
- **Between**, device would start recording when temperature falls in between the temperature range preset.

☞ Auto Start

Device automatically starts recording on the specific date/time preset, no need to press **Start/Stop** button after configuration.

LCD Screens after Configuration



Start Delay

LCD displays “Stby” after configuration.



Temperature Start

LCD displays “▲”(Over), “▼”(Under) or “▲” (Between) above “Stby” indicating temperature start is enabled after configuration. Then you need to press **Start/Stop** button to active logger to measure current temperature condition.



Auto Start

LCD displays “Stby” and a **Clock** after configuration indicating logger is waiting for **Auto Start** on pre-set time.

➤ Repeat Start

Repeat Start is an independent option of Startup, if enabled, you could restart Alpha data logger for next round of monitoring with the same recording parameters of previous recording by pressing Start/Stop button, no need to program the logger again.



“rPt” flashes for about 5 seconds indicating you are about to re-start recording, you are allowed to cancel restart operation at any time during flashing.

-
- Repeat Start is only effective after recording is stopped.
 - Repeat Start is only available for multi-use model.
-

➤ Disable Stop Button

This option is used to avoid mistaken Stop Button action, once enabled, device could not be stopped by pressing **Start/Stop** button, recording will stop when logging cycle ends up, however, you are still allowed to stop recording with TempCentre.

→ Alarm Settings

↻ Alarm Mode

- No alarm setting
- High & Low alarm, 2 alarm ranges determined by 2 alarm limits.
- Multiple Alarm ranges, 5 alarm ranges determined by 5 alarm limits.
 - High range: A1, A2, A3
 - Ideal range: A4 (No alarm will be triggered when data falls within this range)
 - Low range: A5, A6

■ Alpha TH30 does not support multiple alarm ranges.

↻ Alarm Type

- **Single Event**
Alarm could only be triggered when data over/under alarm limit for a consecutive time not less than alarm delay.
- **Cumulative Alarm**
Alarm could be triggered once the cumulatively total time data within alarm range is not less than alarm delay.

→ PDF Report Settings

↻ PDF Report Title

This report title would be used for PDF report created automatically by data logger.

↻ Time Base

Select Time Zone and enable/disable Day Light Saving time (DST) for PDF report.

↻ Language

Select language for PDF report.

Recording

Start recording

→ Manual Start

Press and hold **Start/Stop** button for **3** seconds to manually active data logger, if a logger is set with following start conditions, then recording would only start after these conditions are fulfilled.

☞ Start Delay

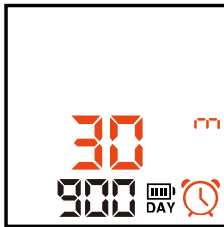

Start delay time and a **Clock** display on LCD and logger begins countdown after activated, frequency of countdown refreshes as per delay time remains, for example, when there is 2 hours left, delay time refreshes each hour, 30 minutes left, LCD refreshes each 1 minute.
(In this case, start delay time is 30 minutes)

☞ Condition Start (Temperature Start)

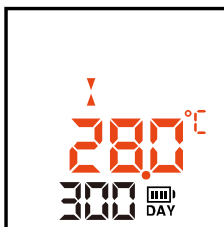

LCD displays current temperature reading after logger activated manually, reading refreshes every 30 seconds. Logger will change to recording status after temperature condition is met.

→ Auto Start

Device starts recording on pre-set time automatically.

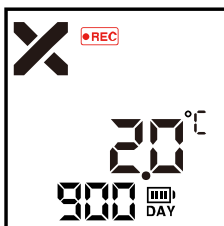

“REC” appears in upper middle screen indicating logger is currently recording.

In Recording

→ Overall Alarm Status (Default Screen)

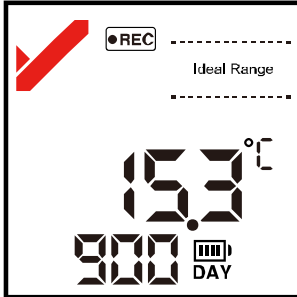

No Alarm Condition

A "Tick" ✓ appears in upper left corner of screen.

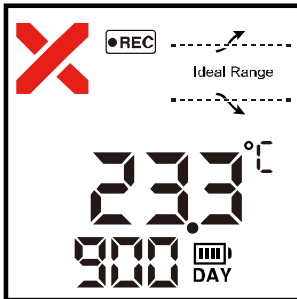

Alarm Triggered

A "Cross" ✗ appears in upper left corner of screen when any pre-set alarm is triggered.

→ Overall Limit Violation Events (Default Screen)

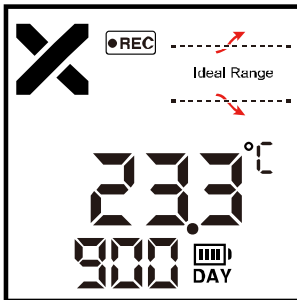

Limit Violation Indication (High & Low Alarm Setting)

High and low limit have been violated in this case

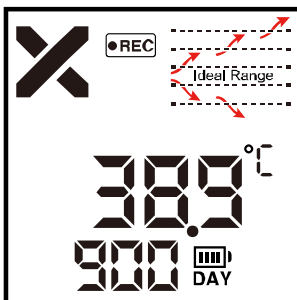

Limit Violation Indication (Multiple Alarm Ranges)

All 5 limits have been violated in this case.

→ **Monitoring Statistics and Alarm Information**

Click **View/Mark** to view monitoring statistics and alarm information screen by screen.

Logging Statistics (Examples)

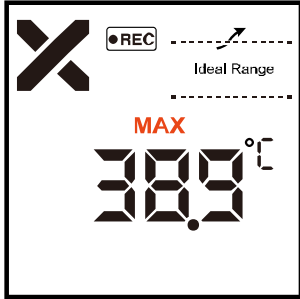

Maximum Value

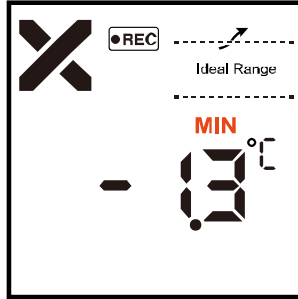

Minimum Value

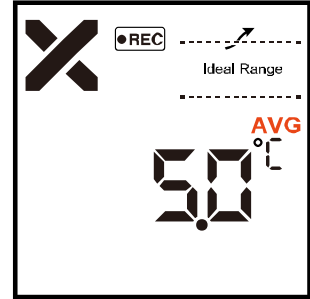

Average Value

Information of Each Alarm Zone (Examples)

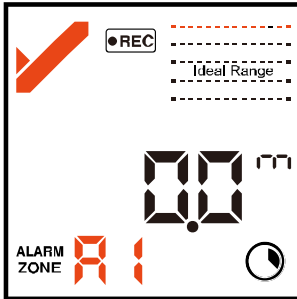

Alarm Zone:A1

- Duration time: 0 minute
- Limit violation event of this zone: No
- Status of this zone: OK

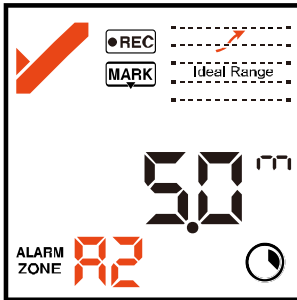

Alarm Zone:A2

- Duration time: 5 minutes
- Limit violation event of this zone: Yes
- Status of this zone: OK

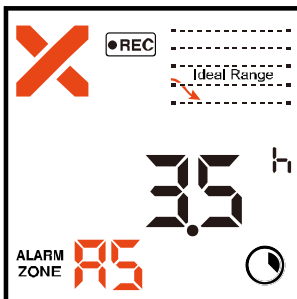

Alarm Zone:A5

- Duration time: 3.5 hours
- Limit violation event of this zone: Yes
- Status of this zone: Alarm

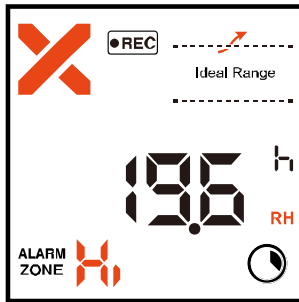

Alarm Zone: High (Humidity)

- Duration time: 19.6 hours
- Limit violation event of this zone: Yes
- Status of this zone: Alarm

Channel sign "RH" displays in down right corner.

Mark History

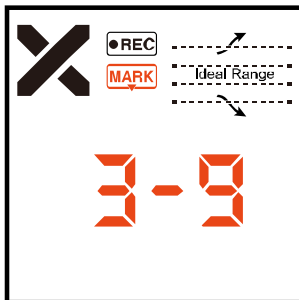

Mark History

In this case, 3 marks have been placed.

Time Mark

Adding a Time Mark

During recording, press and hold **View/Mark** button for several seconds, LCD screen will change to Mark mode, and a "MARK" flashes in upper display indicating a mark is about to be placed.

To successfully add a time mark, please hold the **View/Mark** button throughout the whole process, a maximum of 9 marks are available for adding. A timestamp would be written in logger every time you add a mark, all marks added would be plotted in graph and data list in report.

You could also add alias to time mark of important event for better recognition.

Trimming Data with Mark points

TempCentre software allows user to trim each data record using mark points placed during recording, that means by taking advantage of placing mark points in transit, user could obtain a data record that makes sense for evaluation.

Stopping recording

Press **Start/Stop** button and hold for **3 seconds** to stop recording, logger would stop recording either after logging cycle finishes (memory full).

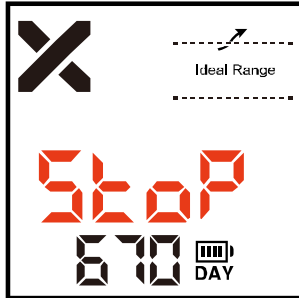

Recording Stops

“StoP” displays indicating recording stops.

-
- Alpha TD80S could not be stopped within 30 minutes after started.
-

Downloading Data

→ **Downloading data via TempCentre**

Connect logger to PC, open TempCentre software, and click **Download** in toolbar, then TempCentre would search, connect logger and download data automatically.

Please remember to save data to data base of TempCentre by clicking **“Apply”** button in software.

→ **Accessing data by copying PDF report**

For models supporting automatic PDF report generation, there is an easier way to achieve data, connect logger to USB port of PC, data logger will start generating PDF report and it may take couple of seconds for the process to complete.



*LCD displays **“PDF”** indicating logger is generating PDF report.*

Open a removable storage device named **TempSenDisk** in computer, copy the PDF report to where you want it to be, and then open and view it with Adobe PDF reader.

-
- Logger would be ready for communication with TempCentre software only after PDF report is completely created.
-

PDF Report

The PDF report automatically created by Alpha loggers are protected and encrypted from tamper, with all raw data embedded, you are allowed to open this PDF file with TempCentre for further analysis and archiving, and upload it to TempSen's **Cold Chain Cloud™** online data management, analysis and sharing center, www.coldchaincloud.com, to enable shipment build and worldwide data sharing, alarm notification between shipper, receiver and QA management personnel.

Authenticity and integrity of PDF reports created by Alpha data loggers could be verified via TempCentre (version 2.0 or higher) or Cold Chain Cloud™ platform.

IMPORTANT



Please DO NOT save the PDF report that you copied from logger as a new file. Please do not perform any Save action through PDF reader. Otherwise, PDF file will be reorganized by Adobe PDF reader and cause raw data inside PDF file unrecognizable.

Please DO NOT remove Alpha data logger from USB port while it's still in the process of creating PDF report ("PDF" on LCD indicates that logger is creating PDF report). Otherwise logger would be seriously damaged.

-
- PDF report format complies with PDF 1.4.
-

PDF Report Sample

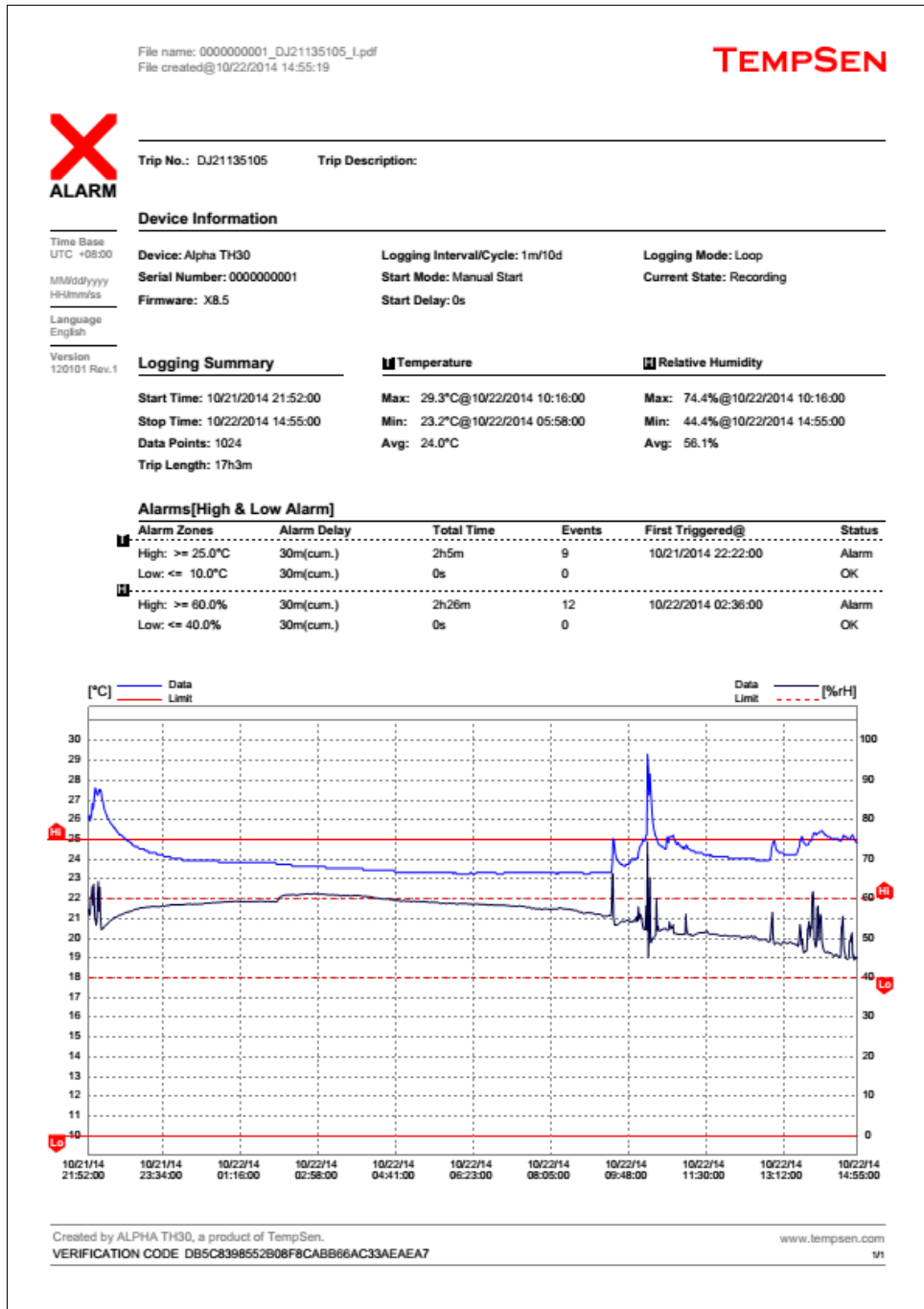

Please go to www.coldchaincloud.com to get latest information about Cold Chain Cloud™ online data storage and sharing service.

Battery and Duration

Alpha series data loggers are installed with lithium battery welded, therefore users could **NOT** change the batteries themselves, any behavior related to battery removing, changing, and charging is deemed as modification to device and will lead to breach of WARRANTY terms.

Battery Life/Run Time

Remaining battery life or run time of each Alpha logger is shown in days on LCD, battery life will minus one day very calendar day after first configuration.

-
- Battery life for single use model Alpha logger will start to deduct after recording started.
-



*Remaining battery life/run time displays in days.
(In this case, remaining battery life is 900 days.)*

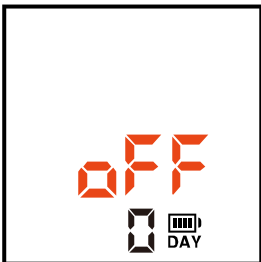

LCD displays "oFF" indicating battery runs out.

Logger would only be allowed to be kept idle for certain period of time, please refer to respective shelf life in specifications published. Battery expiry date is printed on rear of each Alpha logger, any use outside of expiry date would not be guaranteed.

Accessories

External Sensor Probes

→ Installing and Removing External Probe

Please Hold the Connector of the external probe to install and remove probe.

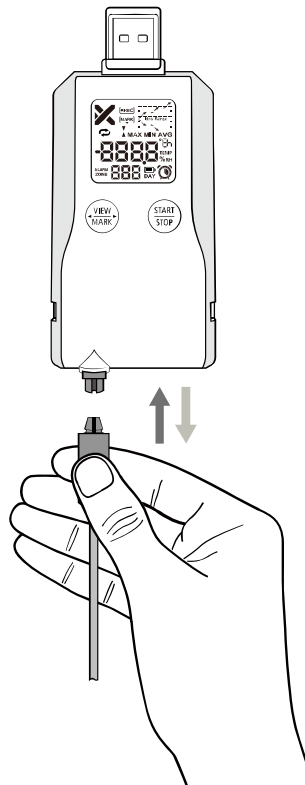

LCD displays “n.C.”(No Connection) when external sensor probe is removed, please connect probe back to device to proceed.



IMPORTANT

- Removal of external probe from device during recording would cause recording stop.
- Removal of external probe from device after configuration may cause startup failure.

Mounting Bracket

The bracket provided along with products allows data logger to be mounted on wall, refrigerator door and shelf using screws, double sided tapes and magnet.

Please install the logger in bracket from bottom up.

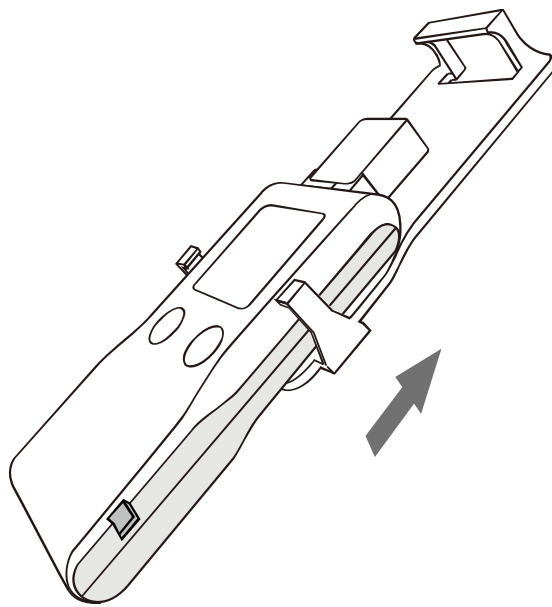

-
- Bracket is not provided with Alpha TD80/TD80S.
-

Calibration Management

Enable calibration expiry notification through TempCentre.



Within 30 days before calibration is due, LCD displays “CAL.” (Calibration) to remind user of renewing calibration for current device.

Sensors

Response Time (Temperature)

→ Response Time Test

T90 response time is the time needed for the recorded value to reach 90 % of the actual change of applied temperature in the conditions mentioned below.

Start Temperature : **20°C**

Target Temperature: **0°C**

Model	T90
Alpha T30/TD80/TD80S	10 minutes
Alpha TH30	10 minutes
Alpha T50X, TUX	5 minutes

MKT

MKT (Mean Kinetic Temperature) is a simplified way of expressing the overall effect of temperature fluctuations during storage or transit of perishable goods. Calculation,

$$T_{mkt} = \frac{\Delta E/R}{-\ln\left(\frac{e^{-\frac{\Delta E}{RT_1}} + e^{-\frac{\Delta E}{RT_2}} + \dots + e^{-\frac{\Delta E}{RT_n}}}{n}\right)}$$

ΔE = activation energy (standard value: 83.144 kJ/mol)

R = 8.314472 J/mol (universal gas constant)

T = temperature in degrees K

n = the number of sample periods over which data is collected

Note: ln is the natural log and ex is the natural log base.

Why is MKT important in the life of pharmaceuticals and perishable goods?

The pharmaceutical and food industries are two closely regulated markets. The FDA provides regulations that require

warehouse and shipment temperatures to be closely controlled and monitored. In addition, the FDA requires well-documented verification of these storage environments and any corrective actions taken if temperatures exceed specified storage conditions.

Time Error

Time recording deviation of Alpha data logger is 2 minutes every month.

Additional Information

- LCD may function abnormally after taken out from environment down to -20°C to room temperature, please wait for few minutes for it to restore to normal status.
- To avoid damaging your Alpha data logger, please do not disconnect it from USB port while it is communicating with the computer.
- Do not use any aggressive cleaning agents or solvents to clean device.
- Data stored in Alpha logger is retrievable even battery runs out.
- Please do not heat, microwave or recharge battery of Alpha data logger.
- Please follow local regulations when recycling or disposing of Alpha data logger.

Warranty

TempSen warrants this TempSen-branded hardware product against defects in materials and workmanship under normal use for a period of ONE (1) YEAR from the date of retail purchase by the original end-user purchaser ("Warranty Period"). If a hardware defect arises and a valid claim within the Warranty Period, as its option and to the extent permitted by law, TempSen will either (1) repair the hardware defect at no charge, using new parts or parts equivalent to new in performance and reliability, (2) exchange the new product with a product is new or equivalent to new in performance and reliability and is at least functionally equivalent to the original product, or (3) refund the purchase price of this product. TempSen may request that you replace defective parts with new or refurbished user-installable parts that TempSen provides in fulfillment of its warranty obligation. A replacement product or parts, including a user-installable part that has been installed in accordance with instructions provided by TempSen, assumes the remaining warranty of the original product or ninety (90) days from the date of replacement or repair, whichever provides longer coverage for you. When a product or part is exchanged, any replacement item becomes your property and the replaced item becomes TempSen's property. Parts provided by TempSen in fulfillment it's warranty obligation must be used in products for which warranty service is claimed. When a refund is given, the product for which the refund is provided must be returned to TempSen and becomes TempSen's property.

EXCLUSIONS AND LIMITATIONS

This Limited Warranty applies only to the hardware product manufactured by or for TempSen that can be identified by the "TempSen" trademark, trade name, or logo affixed to it. The Limited Warranty does not apply to any non-TempSen hardware product or any software, even if packaged or sold with the TempSen hardware. Manufacturers, suppliers, publishers, other than TempSen, may provide their own

warranties to the end user purchaser, but TempSen, in so far as permitted by law, provides their products “as is”. Software distributed by TempSen with or without the TempSen brand name (including, but not limited to system software) is not covered under this Limited Warranty. Refer to the licensing agreement accompanying the software for details of your rights with respect to its use.

TempSen does not warrant that the operation of product will be uninterrupted or error-free. TempSen is not responsible for the damage arising from failure to follow instructions relating to the product's use.

This warranty does not apply: (a) to consumable parts, such as batteries, unless damage has occurred due to a defect in materials or workmanship; (b) to cosmetic damage, including but not limited to scratches, dents, and broken plastic on ports; (c) to damage caused with non-TempSen products; (d) to damage caused by accident, abuse, misuse, flood, fire, earthquake, or other external causes; (e) to damage caused by operating the product outside the permitted or intended uses described by TempSen; (f) to damage caused by service (including upgrades and expansions) performed by anyone who is not a representative of TempSen or TempSen Authorized Service Provider; (g) to a product or part that has been modified to alter functionality or capability without the written permission of TempSen; or (h) if any TempSen serial number has been removed or defaced.

IMPORTANT: DO NOT OPEN THE HARDWARE PRODUCT. OPENING THE HARDWARE PRODUCT MAY CAUSE DAMAGE THAT IS NOT COVERED BY THIS WARRANTY. ONLY TEMPSSEN OR AN AUTHORIZED SERVICE PROVIDER SHOULD PERFORM SERVICE ON THIS HARDWARE PRODUCT.

Revision History

Revision	Date	Details
C	03/16/2015	Battery life for single use alpha logger changes to deduct 1 day each calendar day after recording started.
D	07/06/2015	Added caution for saving auto PDF report



Shenzhen EO Technology Co., Ltd.

Tel : (+86 0755)8420 0058
Fax : (+86 0755)2571 2314
Email: sales@eofirm.com
Website: www.eofirm.com